



FELTWORKS[™]
ACOUSTIC
BAFFLES

QUIET

Soft Visual Texture
made for
MODERN
INTERIORS

FELTWORKS™ Acoustic Baffles

Define the Personality of Your Space

FELTWORKS™ Baffles transforms mundane to modern with a soft visual texture that quietens down interiors.

Reduce noise and define spaces. FELTWORKS Baffles absorb up to 80% of the sound that strikes them.

Easy installation with standard aluminium suspension carrier and engineered suspension systems.

Homogeneous structure – color throughout panels. Eco-Preferable product which meets the most stringent industry sustainability standards today.

FEATURES AND BENEFITS

- Excellent sound absorption properties
- Suitable for wall and ceiling applications
- Eco-preferable material with low VOC emission, contains no formaldehyde and high recycled content
- Homogeneous with throughout color – No field paint required for cut edges
- Cleanable and easily demountable
- Multiple installation method with engineered suspension systems and accessories
- Impact and scratch resistant for long material longevity



APPLICATION CONSIDERATION

- Surface has inherent directional grain feature due to fibre blending process.
- Panel color and texture may vary from order to order; adequate attic stock should be ordered.
- FeltWorks Baffle panels are for interior application only
- FeltWorks Baffle panels should not be installed near sources of heat greater than 60 degree celsius.

SHORT SPECIFICATION

To supply homogeneous acoustical baffles system made from non-woven layered and formed polyester felt fiber panel with minimum 50% recycled content.

The system shall be FELTWORKS Baffles at 2800 mm length x (150/200/300mm Classic) or (150mm Curves) x 12 mm thickness, color (), manufactured by Armstrong Ceiling Solutions with ten (10) years limited warranty. Panel shall be impact resistant, scratch resistant and unaffected by moisture, mold and mildew and remain dimensionally stable up to relative humidity 99% at 49°C.

Installation: Acoustical polyester baffle system shall be (independently suspended with aircraft cable kit) / (group installed with spacing at ()mm interval installed as per manufacturer instructions.

FELTWORKS™ Standard Baffle Kit Options

VISUAL SELECTION

Install Profile (Modules)	Item Number	Description	Nominal Dimension (D x L x Thickness)
<p>Classic 150mm</p>	FWBR150_ _ _	Feltworks Baffles 150mm Rectangular 16 pcs per kit	150mm x 2800mm x 12mm Per pack is designed to cover up to 6.72 m² at 150mm panel interval
<p>Classic 200mm</p>	FWBR200_ _ _	Feltworks Baffles 200mm Rectangular 12 pcs per kit	200mm x 2800mm x 12mm Per pack is designed to cover up to 6.72 m² at 200mm panel interval
<p>Classic 300mm</p>	FWBR300_ _ _	Feltworks Baffles 300mm Rectangular 8 pcs per kit	300mm x 2800mm x 12mm Per pack is designed to cover up to 6.72 m² at 300mm panel interval
<p>Curves</p>	FWBC200_ _ _	Feltworks Baffles 200mm Curves 12 pcs per kit	Varies x 2800mm x 12mm Per pack is designed to cover up to 6.72 m² at 200mm panel interval

DESIGN – FOCUS SERIES

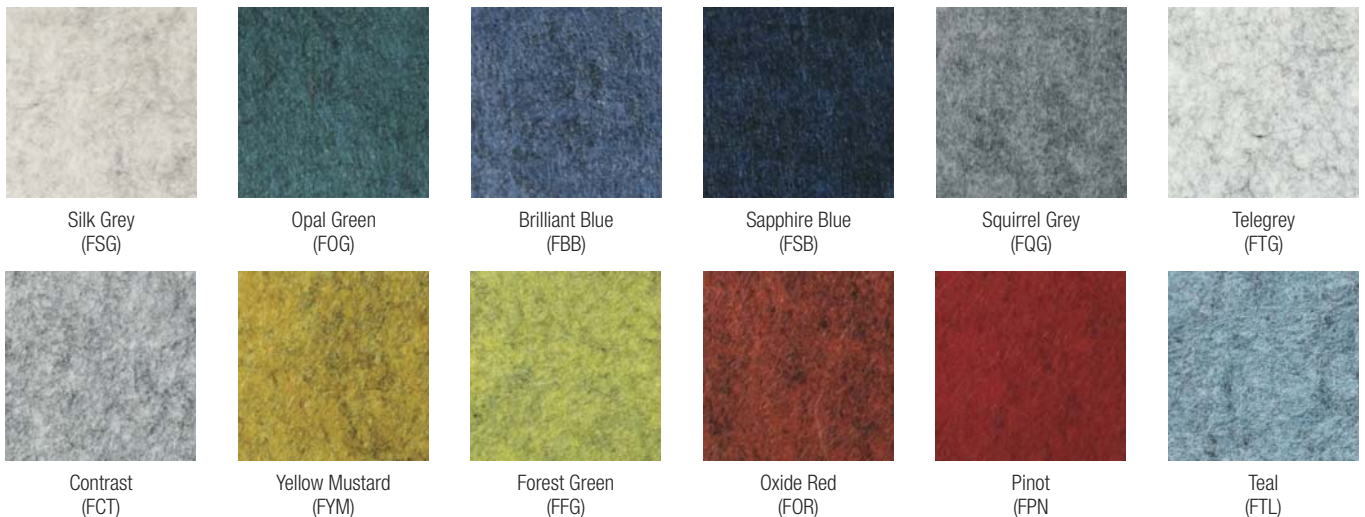

- PLEASE NOTE:**
1. When specifying or ordering, add 3-letter color suffix to item number.
 2. Accessories for installation shall be ordered separately to suit either independent hang or group installation.
 3. All blades in a kitted module must be the same color. For custom shapes, sizes, and layouts, contact your Armstrong representative.
 4. Variations may occur between photographic images, samples and batches in terms of color, shade and pattern.

FELTWORKS™ Standard Baffle Kit Options

PERFORMANCE

FELTWORKS Baffles can absorb up to 80% of noise which strikes on surface. Equivalent to NRC 0.80 in accordance to ASTM C423.

Advisory: Spacing between panels might influence overall planar absorption performance.

MATERIAL TECHNICAL DATA

Color Fastness	EN ISO 105 B02 method 3	Grade 6-7
Water Vapor Absorption	ASTM C1104/C1104M	<0.4%
Impact resistance	ISO 7892	Passed
Mold & Mildew Resistance	ASTM G21	Rating '0'
No Toxicity	BS EN 45545-2	Passed
Fire Reaction	EN13501-1	Bs2-d0

SUSPENSION SYSTEM and ACCESSORIES

Item	Description	Color	Pcs./Ctn
FW12KIT	FW12 Aluminium Trim for 12mm Baffles (Incl. 2 x Eye Bolt & Nuts , 1 x FW12 Connector)	Anodized Aluminium	2 Pc / Kit
BPFW5548	Prelude Hanger Kit (Group Installation Option 1)	–	4 Assembly / Kit
BPFW5547	U-Profile Hanger Kit (Group Installation Option 2)	–	4 Assembly / Kit
BPFW5135	Hanger Wire Kit with enlarged hook	–	4 Assembly / Kit

* Standard Feltworks baffle requires 1 piece of FW12 aluminum trim. Accessories required to be ordered separately.

INSTALLATION

FELTWORKS Baffles is completed with integrated FW12 aluminium trim and eye bolt kit for easy alignment and installation – no special preparation or assembly is needed on site. Simply fix using a standard grid suspension system, U-Profile Suspension system or hang individually for soffit. Group suspension elements shall be ordered separately as required.

BPFW5135



BPFW5548



BPFW5547



FW12KIT

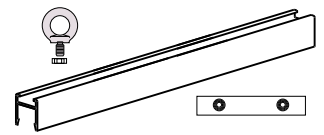

Typical Group Installation Schematic

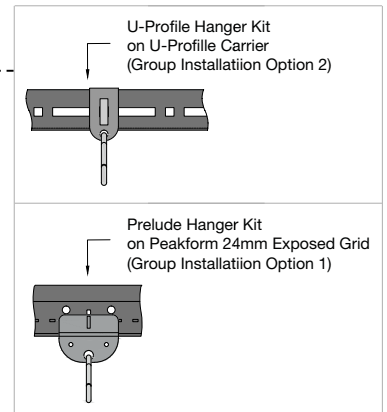
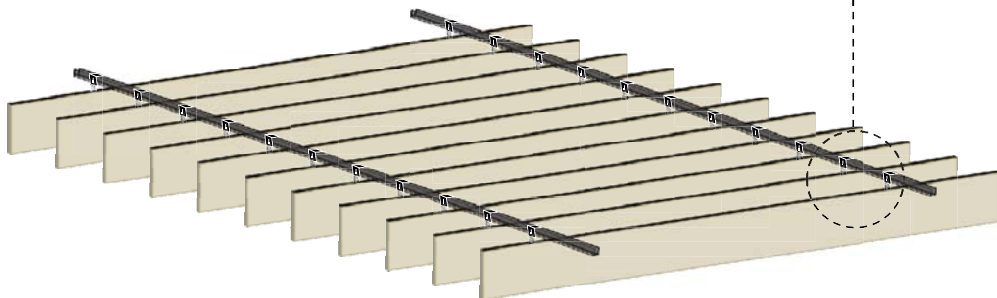

www.knaufarmstrong.com
@ Armstrong Ceilings Asia

Produced 24 July 2020



Follow us on Facebook & LinkedIn for design advice, technical expertise and the latest case studies, as well as new product developments and to keep up to date with current industry news and views.